

fluidlink HYDRAULICS

SERIES 35 VALVES

A range of bankable solenoid valves and modules compatible with most mini power packs

New Concept
Compact
Lower weight
Modular system

Max pressure (P A B) 250bar
Max pressure (T) 140bar
Flow rate up to 30l/min

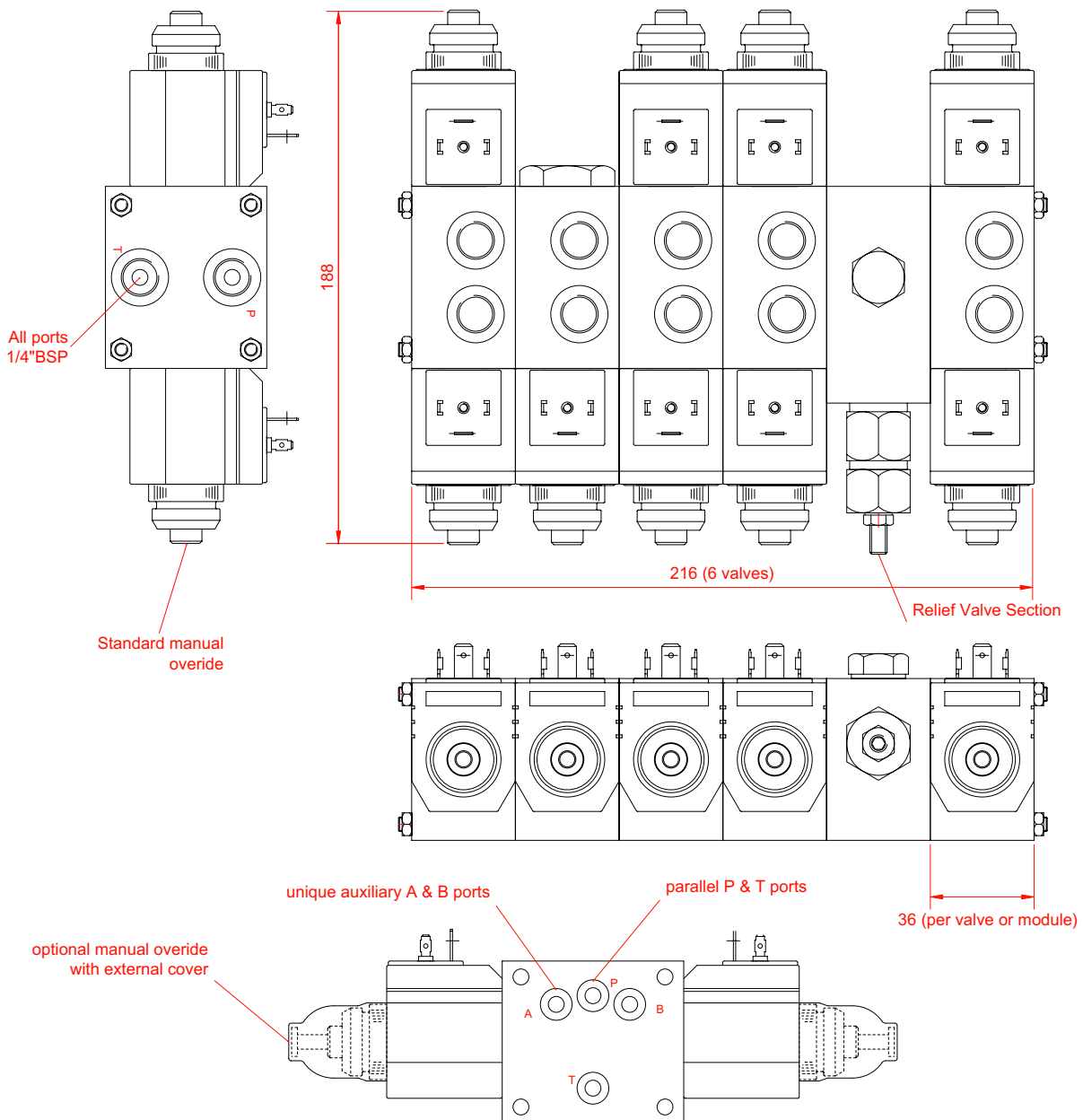

fluidlink

SERIES 35 VALVES

Technical Specification

Max pressure (P&T)	250bar
Max pressure (T)	140bar
Flow rate	up to 30l/min
Spool leakage (max at 70bar)	30cc/min
Weight	1,1kg to 1,5kg each
Solenoid power	30W (nominal)
Voltage tolerance	±10%
Max fluid temperature	80°C
Tightening torque on tie rods	6Nm

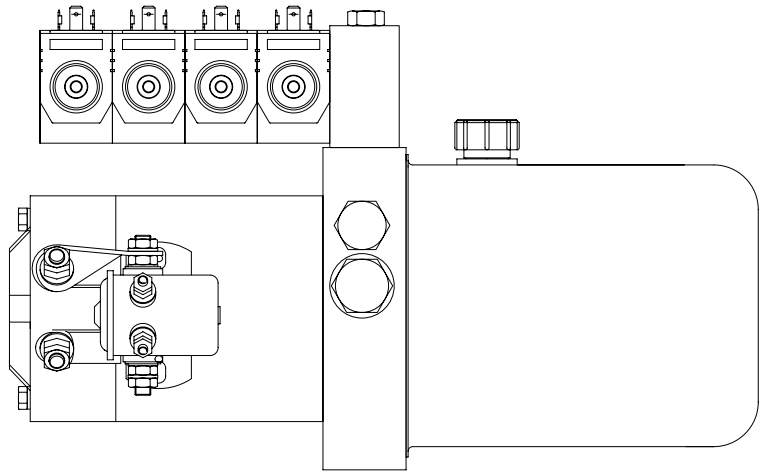

Series35 bank fitted to typical Mk3c Pack

Use adaptor block kit Part Number

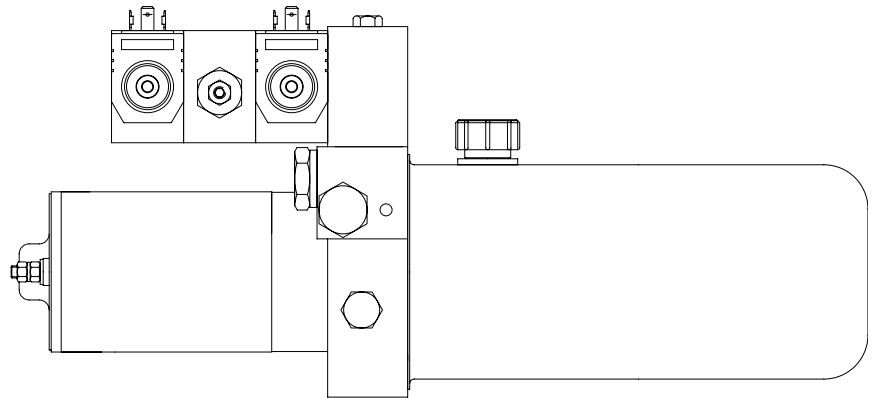
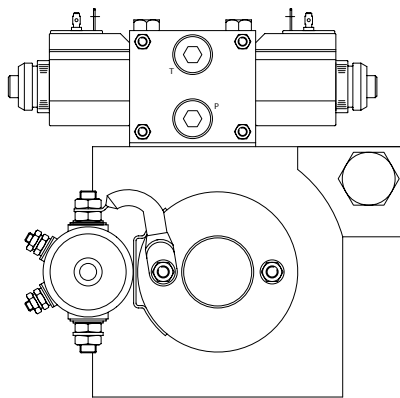

Series35 bank fitted to typical Slimline Pack

Use adaptor block kit Part Number

Dimensions of typical valve section.

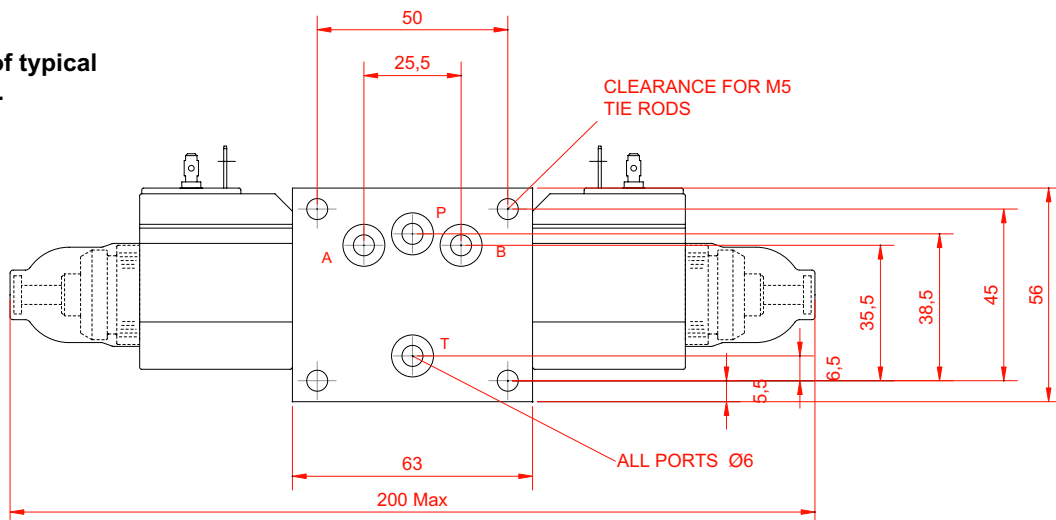

fluidlink

SERIES 35 VALVES

Pressure drop figures for each valve section using hydraulic oil of 35cSt viscosity. Pressure drop is independent of body type. Curve 1 is also pressure drop through P and T galleries for a typical 4-bank assembly.

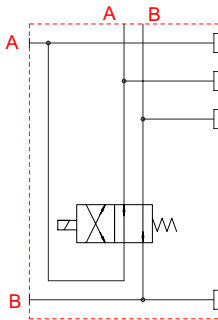
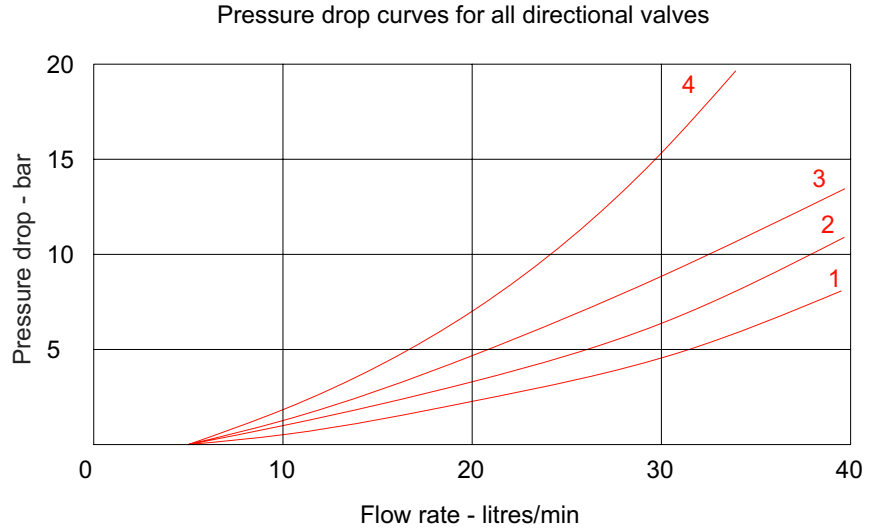

AMO Spool

P to Service 2
Service to T 3

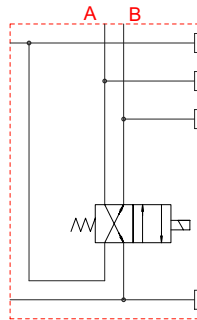

BMO Spool

P to Service 2
Service to T 3

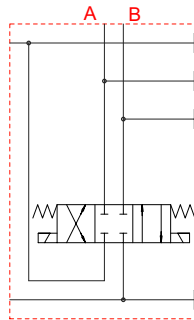

DAO Spool

P to Service 3
Service to T 3

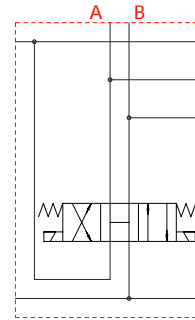

DBO Spool

P to Service 2
Service to T 2
P to T (N) 2

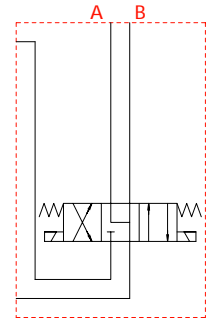

DFO Spool

P to Service 3
Service to T 1
P to S'ce (N) 4

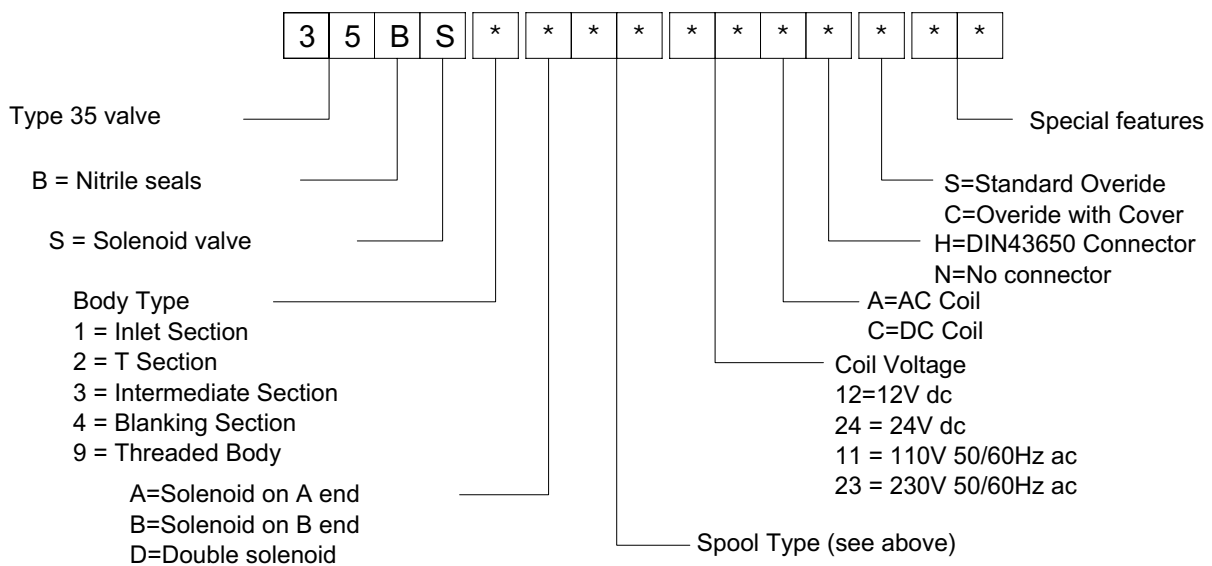

fluidlink

HYDRAULICS

SERIES 35

VALVES

Unique Module Valves

Valve modules work with the unique side ports in the main solenoid section to provide auxiliary controls without adding to the height of the bank. The standard modules shown below combined with an almost endless variety of custom-designed modules provides a solution for any hydraulic control system.

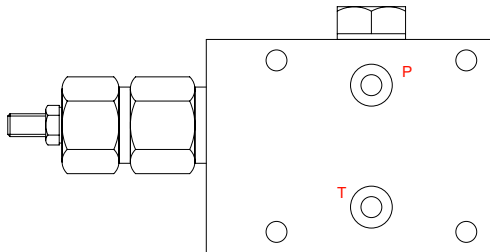

P to T Relief Module

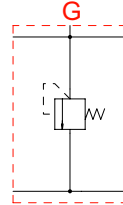

Symbol

Ordering Code: 35BM-R4

Use as main system relief valve except when fitted to a mini pack when the pack relief valve can be used.

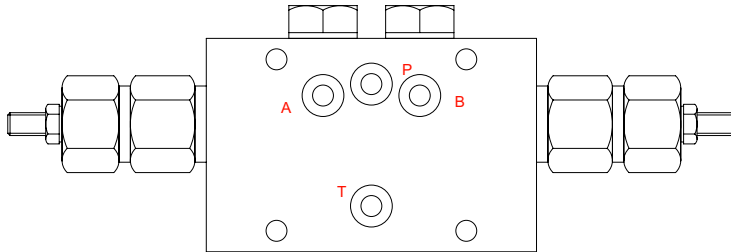

Service Port Relief Module

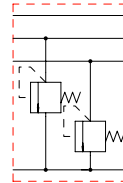

Symbol

Ordering Code: 35BM-SAB

Fit this module to control each service port pressure below the main relief valve setting.

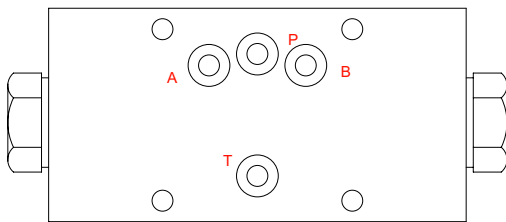

Pilot Operated Check Module

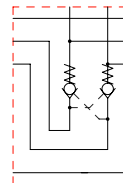

Symbol

Ordering Code 35BM-DD
35BM-DA or DB

For positive load-holding. Available as Double (DD) or just on one port (DA or DB). Use with type F or B spool on associated solenoid valve.

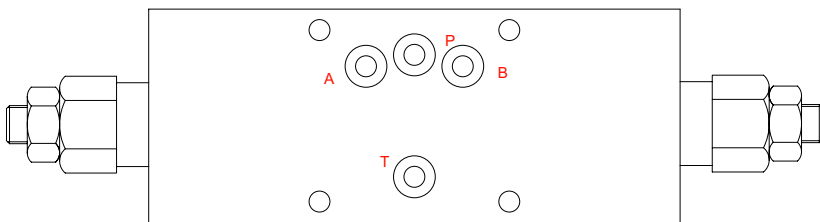

Counterbalance Module

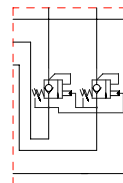

Symbol

Ordering Code 35BM-CBD
35BM-CBA/CBB

For positive load-holding but will control over-running loads and also act as safety port relief valve. Use with type F or B spools.